

SITE PREPARATION GUIDE

SP100 Automation Instrument

Notice

© 2021 Seer, Inc. All rights reserved. Information in this document is subject to change without notice. Seer assumes no responsibility for any errors or omissions in this document. Duplication and/or reproduction of all or any portion of this document without the express written consent of Seer is strictly forbidden. Seer does not convey any license under its patent, trademark, copyright, or common-law rights nor similar rights of any third parties by this document.

Nothing contained herein shall constitute any warranty, express or implied, as to the performance of any products described herein, or any warranties of merchantability, fitness for a particular purpose or non-infringement. The use of products described herein is subject to certain restrictions as set forth in the applicable terms and conditions of sale or license accompanying the purchase of such product and any written agreements between Seer and user. Seer may refer to products or services offered by other companies by their brand names or company names solely for clarity and does not claim any rights in those third party marks or names. All products and services described herein are intended FOR RESEARCH USE ONLY and NOT FOR USE IN DIAGNOSTIC PROCEDURES.

The instructions in this document must be strictly and explicitly followed by qualified and properly trained personnel in order to ensure the proper and safe use of the product(s) described herein. All of the contents of this document must be fully read and understood prior to using such product(s).

Failure to completely read and explicitly follow all of the instructions contained herein may result in damage to the product(s), injury to persons, including to users or others, and damage to other property, and will void any warranty applicable to the product(s). Seer does not assume any liability arising out of the improper use of the product(s) described herein (including parts thereof or software).

USER IS NOT LICENSED OR AUTHORIZED TO, AND AGREES NOT TO, USE ANY SEER PRODUCT FOR ANY CLINICAL OR DIAGNOSTIC PURPOSES.

This manual may not be used or reproduced in any manner without the express written consent of Seer, Inc.

© 2021 Seer, Inc. All rights reserved.

Seer and Proteograph are trademarks of Seer, Inc.

SpectraMax is a trademark of Molecular Devices.

Sorval is a trademark of Thermo Fisher Scientific.

Centrivap is a registered trademark of Labconco.

Revision history

DOCUMENT	DATE	DESCRIPTION OF CHANGE
CF-1017 B	December 2021	General availability release
CF-1017 A	June 2021	Limited (early access) release

Contents

Notice	2
Revision history	3
Contents	4
Introduction	5
Installation time	5
Safety considerations	5
Laboratory requirements	6
Instrument dimensions	6
Placement requirements	7
Pressurized gas	7
Network setup	7
Environmental constraints	8
Electrical requirements	8
Power cords	8
Fuses	8
Electromagnetic considerations	8
Noise level	8
Instrument delivery and installation	9
Crate contents	9
Crated dimensions and weight	9
Delivery dimensions	9
Elevator clearance	9
Doorway clearance	10
Required equipment	11
Additional required material	12
Deionized water quality requirements	13
Site readiness	14
Delivery considerations	14
Delivery contact	14
Installation site	14
Crate condition	15
Acceptance	15

Introduction

The SP100 Automation Instrument automates liquid handling for converting proteins into peptides, as well as other liquid handling workflows. The instrument is installed at your site by a Seer™ field service engineer (FSE). Post installation, a Seer field application scientist (FAS) trains your staff on its proper use.

A Seer representative will schedule the installation with you. Prior to the installation, you must prepare your site per this guide to ensure safety and performance.

If your site requires special shipping arrangements or has considerations outside the scope of this guide, notify your Seer representative.

Installation time

Instrument installation and qualification typically take five days:

- **Days 1–2:** The Seer FSE installs the instrument and completes initial instrument testing to assess general performance.
- **Day 3–5:** The Seer FSE/FAS completes a series of tests to determine if the instrument is installed correctly and performs per product specifications.

Make sure that you have staff available to oversee delivery, installation, and training on the applicable days. Four people who can each lift 80 lb. (36 kg) are required.

CAUTION

After installation, do not attempt to lift or move the instrument.

Safety considerations

Review the *Proteograph™ Product Suite User Guide (CF-1016 B)* for important information about environmental health and safety.

Laboratory requirements

The following sections provide detailed specifications to ensure that your laboratory can accommodate the instrument, custom table, and peripherals.

Instrument dimensions

The following information provides the dimensions of the installed SP100 and custom table, which ships with the instrument. These dimensions cannot be modified.

An ergotron arm presents a touchscreen monitor that you can position in front the instrument and rotate as needed. The FSE assembles the arm.

Figure 1. Dimensions of the installed instrument and table

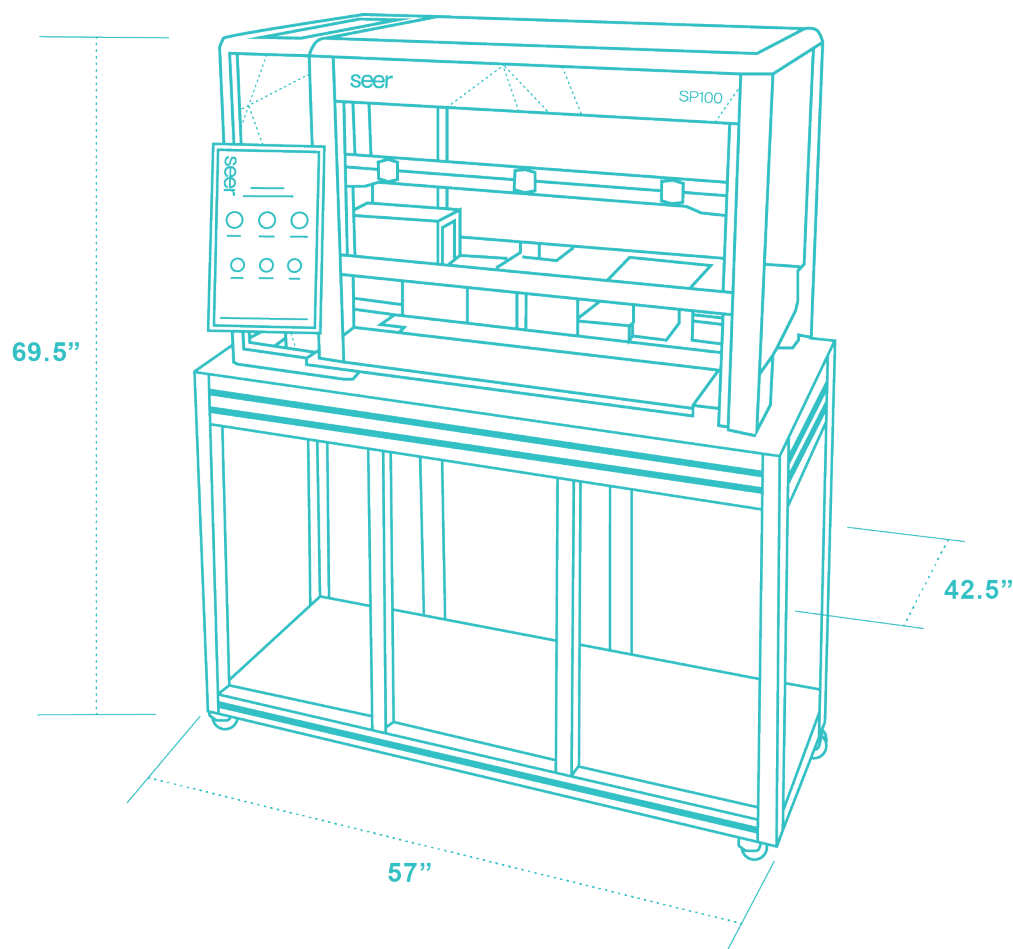

COMPONENT	LENGTH	WIDTH	HEIGHT	WEIGHT
Instrument	57 in. (145 cm)	40 in. (102 cm)	36 in. (91 cm)	331 lb. (150 kg)
Table	57 in. (145 cm)	43 in. (109 cm)	34 in. (86 cm)	Not applicable

Placement requirements

Consider the instrument dimensions and position the SP100 in a space that allows personnel to access the front and sides of the instrument for operation and maintenance purposes and to open and close the front protective cover. Allow sufficient space for a person to comfortably move and work and easily access the power button and power cord.

NOTE

Field support might later require access to the back of the instrument.

Make sure that obstacles in the surrounding area do not impair the ventilation outlets of the instrument. Make sure there are four 115–230 VAC outlets within reach of the instrument's power cords without necessitating a power strip or extension cords.

Do not expose the instrument to open windows, direct sunlight, or intense artificial light. Rapid temperature changes or direct sunlight can affect pipetting accuracy, barcode scanning, and other instrument functions.

Seer also recommends the following:

- Situate an empty lab bench approximately as wide as the instrument either directly opposite the front of the instrument or adjacent to the instrument to facilitate efficient loading of the instrument prior to running the assay.
- Provide a staging area (e.g., a cart, a designated portion of a lab bench) near the instrument on which to set plasticware, reagents, and other materials.

Pressurized gas

The SP100 has a monitored multi-flow positive pressure evaporative extraction (MPE) module that requires pressurized gas for proper operation.

- A 105–110 psi supply of nitrogen or compressed air equipped with an appropriate regulator.
- Quick-connect fitting to accommodate 0.25 in. outer diameter Teflon tubing.
- Minimum capacity of 50 L per minute, inclusive of other devices sharing the supply.

Network setup

The SP100 is installed and tested in a non-networked mode. For proper instrument operation, all automatic updates to Microsoft Windows operating system are disabled and must remain so. Disregarding this requirement can result in failures when processing the Proteograph Assay Kit.

Environmental constraints

ELEMENT	SPECIFICATION
Temperature	15–35 °C (59–95°F) Use in a typical indoor laboratory environment. Extreme temperature conditions affect the sensitive reagents used with the instrument.
Humidity	20–85% relative humidity, non-condensing
Altitude	0–6562 ft. (0–2000 m) above sea level
Ventilation	Ensure instrument ventilation outlets are not impaired by obstacles placed in the surrounding area.

Electrical requirements

For the instrument power supply, ensure access to a 115 or 230 VAC (50 or 60 Hz) electrical receptacle. The instrument automatically recognizes any voltage within that range and does not require intervention. Four power outlets are required.

On standby, instrument power consumption is 100 VA. Maximum power consumption is 600–1000 VA.

Power cords

The main plug is on left side of the instrument.

Use only Seer-supplied power cords and ensure access to a grounded electrical receptacle.

Seer recommends the use of an uninterruptible power supply (UPS) with voltage regulating capacity to prevent damage from power fluctuations.

Fuses

The main power socket contains the fuses for the instrument. The SP100 uses only manufacturer-recommended fuses, which are size 5×20 and rated for 4 and 10 AT, 250 V.

Electromagnetic considerations

Subjecting the SP100 to electromagnetic radio frequency (RF) fields or static electricity discharged directly onto the instrument might impair liquid level detection ability. Keep the instrument away from other equipment that emits electromagnetic RF fields and minimize static electricity in the immediate environment.

Noise level

The instrument operates at a noise level of < 65 dBA. On standby, the noise level is < 46 dBA.

Instrument delivery and installation

Make sure the site is ready for delivery and installation of the SP100. Provide a delivery contact and determine special considerations and readiness by completing the tables, checklists, and forms in [Required equipment](#) (page 11) and [Site readiness](#) (page 14).

Crate contents

The instrument ships in three crates:

- Crate 1: SP100 Automation Instrument
- Crate 2: Chiller unit, instrument computer, MPE module, and peripherals (e.g., chiller power unit, MPE power unit) and accessories
- Crate 3: Custom table

Crated dimensions and weight

CRATE	HEIGHT	WIDTH	DEPTH	WEIGHT
1	50 in. (127 cm)	50 in. (127 cm)	34 in. (87 cm)	446 lb. (202 kg)
2	69 in. (176 cm)	47 in. (120 cm)	31 in. (79 cm)	247 lb. (112 kg)
3	45 in. (115 cm)	63 in. (160 cm)	49 in. (125 cm)	471 lb. (214 kg)

Delivery dimensions

The size of the crated instrument and table require extra attention to ensure safe transport from the delivery location to the prepared site. The following sections provide the requirements for elevator and doorway clearances.

Due to clearance limitations, unpacking the crates before transport to the site might be necessary. In these cases, store the crates in a safe, temperature-controlled location until installation. **Do not unpack the crates without FSE assistance.**

Elevator clearance

Review the following table for the minimum clearances the delivery needs to fit into an elevator with 1 in. excess for the elevator door.

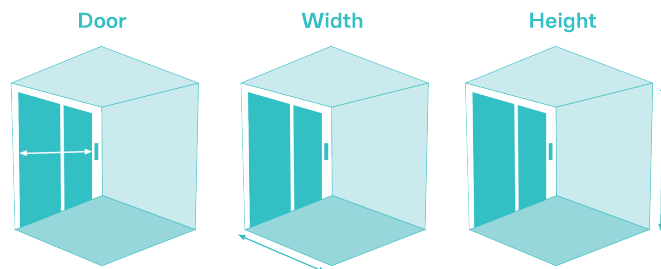

DIMENSION	CLEARANCE
Elevator door	50 in. (127 cm)
Elevator width	78.7 in. (200 cm)
Elevator height	76.2 in. (193.5 cm)

Doorway clearance

Review the following table for the minimum clearances the delivery needs to fit through doorways.

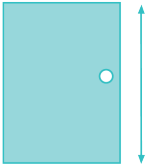
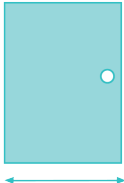
Height	Width	DIMENSION	CLEARANCE
		Door height	76.2 in. (193.5 cm)
		Door width	50 in. (127 cm)

Required equipment

To successfully qualify your SP100, have the following equipment on-site or readily available during installation, qualification, and training. Complete the empty table cells and return the table to Seer before installation.

EQUIPMENT	REQUIREMENT	SUPPLIER	
Liquid chromatography ^{1,2}	Demonstrated proteomic compatibility	Make	
		Model	
		Manufacturer	
Mass spectrometer (MS)	Demonstrated proteomic compatibility	Make	
		Model	
		Manufacturer	
96-well plate adapter for vacuum concentrator	Adapter that fits a vacuum concentrator in a 96-well plate format	Make	Microliter Plate Rotor
		Model	Part # 7461900
		Manufacturer	Labconco
Fluorescence intensity microplate reader	Can measure peptide concentration via fluorescence (375/425 nm) in a 96-well format	Make	SpectraMax
		Model	M2 ^e
		Manufacturer	Molecular Devices
Refrigerated microcentrifuge	Can accelerate samples up to 5000 x g at refrigerated conditions	Make	Sorvall Legend
		Model	catalog # 75002441
		Manufacturer	Thermo Fisher Scientific
Vacuum concentrator	Can dry peptides overnight in a 96-well plate format	Make	Refrigerated CentriVap
		Model	Centrifugal Vacuum Concentrator, part # 7310021
		Manufacturer	Labconco

¹In-line with the MS instrument.

²Seer recommends the use of a trap column coupled to the LC-MS system used for analysis. A trap column removes contaminants and unwanted analytes that could interfere with the analysis of analytes of interest. For assistance with selecting a suitable trap column for your organization's use, contact the manufacturer of your liquid chromatography (LC) system.

Additional required material

Seer provides materials for installation, qualification, and training. The following materials are also required for installation, qualification, and training, but are not provided by Seer.

DESCRIPTION	SUPPLIER	NOTES
1–10 mL pipette with tips	Rainin, material # 17011783	1
20–200 μ L multichannel pipette with tips	Rainin, material # 17013810	1
20–200 μ L pipette with tips	Rainin, material # 17014391	1
100–1000 μ L pipette with tips	Rainin, material # 17014382	1
Disposable latex gloves	General lab supplier	
Lab coats	General lab supplier	
Peptide Reconstitution Buffer	Laboratory prepared	2
Protective goggles	General lab supplier	
Waste Bags with Biohazard Labeling	Hamilton, part # 199203	4
Waste Container Biohazard Box	Hamilton, part # 281520	3

¹Or equivalent.

²For information about preparing the reconstitution buffer, refer to the *Proteograph Product Suite User Guide (CF-1016 B)*.

³Or equivalent with dimensions of 24" W x 24" L x maximum 20" H.

⁴Or equivalent, with dimensions suitable for placement inside waste box.

In addition to the above materials, the site must have a supply of reagent-grade water (18.2 M Ω supply or equivalent), up to 1 L per day. If you expect water supply to be a problem during qualification and training, notify Seer.

Deionized water quality requirements

In its own testing laboratory, Seer uses a PURELAB Chorus 1 Complete water purification system to produce deionized water for the assay. Seer recommends that the water purification system you use to produce deionized water meets or exceeds the following specifications.

PRODUCT SPECIFICATIONS	PURELAB CHORUS 1 COMPLETE 10L/HR	NOTE
Dispense Flowrate	>1.5 L/min	
Inorganics (resistivity at 25 °C)	18.2 MΩ.cm	
Organics (TOC)	<5 ppb	
Bacteria	<0.001 CFU/mL	*
Bacterial Endotoxin	<0.001 EU/mL	*
pH	Effectively neutral	
Particles	0.2 μm	*
DNase	< 5 pg/mL	
RNase	< 1 pg/mL	
Daily Usage (max)	100 L/day	
Daily Usage (min)	1 L/day	
Delivery Flow Rate	10 L/hr	

*With point-of-use filter fitted.

Site readiness

Complete the following checklists and forms and return them to your Seer field service representative. For further assistance, contact the field service representative or Seer support at support@seer.bio or 833-254-7337 (US only).

Delivery considerations

Complete the following checklist to determine whether your site has any special considerations for delivery.

- A loading dock is available. If a loading dock is not available, immediately notify your Seer representative.
- A pallet jack or forklift is available for transferring the crates from the loading dock.
- The site can appropriately store all three crates.
- The dimensions of all elevators, doorways, and passageways that the crates must navigate between the loading dock and laboratory can accommodate the crates.

Delivery contact

Provide the following contact information for the person at your site who is arranging delivery.

Name	
Phone	
Delivery address	

Installation site

The Seer Customer Experience Team coordinates installation of the SP100 and peripherals. Complete the following checklist to confirm that the installation site is ready.

- Unnecessary materials have been removed from the area.
- All three crates shipped from Seer have been received.
- Clearance permitting, the crates have been moved to the site.
- The gas supply can reach the instrument.
- Seer provides 25 ft. of 0.25 in. outside diameter (OD) and 0.1875 in. inside diameter (ID) tubing for connection to the MPE power unit. Additional 0.25 in. OD and 0.1875 in. ID tubing, fittings, gas tanks, and regulators might be necessary.
- Four 115–230 VAC outlets are within reach of the instrument's power cords, without necessitating a power strip or extension cords.
- A clear lab bench is situated either directly opposite the front of the instrument or adjacent to the instrument.

Crate condition

Complete the following checklist to confirm crate condition.

- Without unpacking the crates, check all three crates for signs of external damage.
- Note and report any crate damage to the FAS, FSE, or other Seer representative.

Acceptance

Provide the following information to confirm site readiness by the installation date.

Name	
Signature	
Date	